

# TECHNICAL DATA

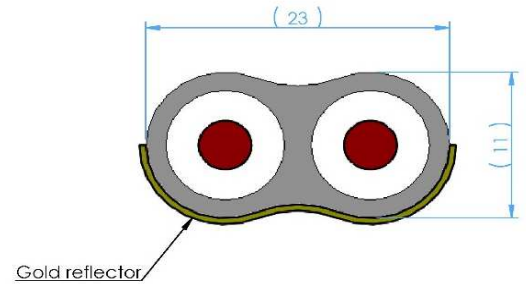
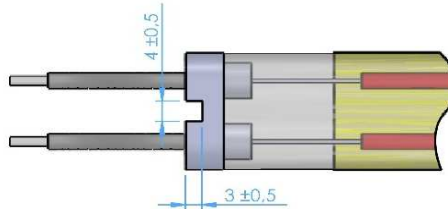
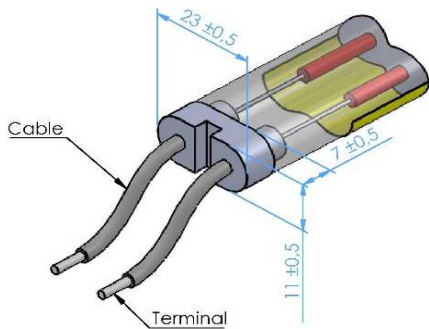
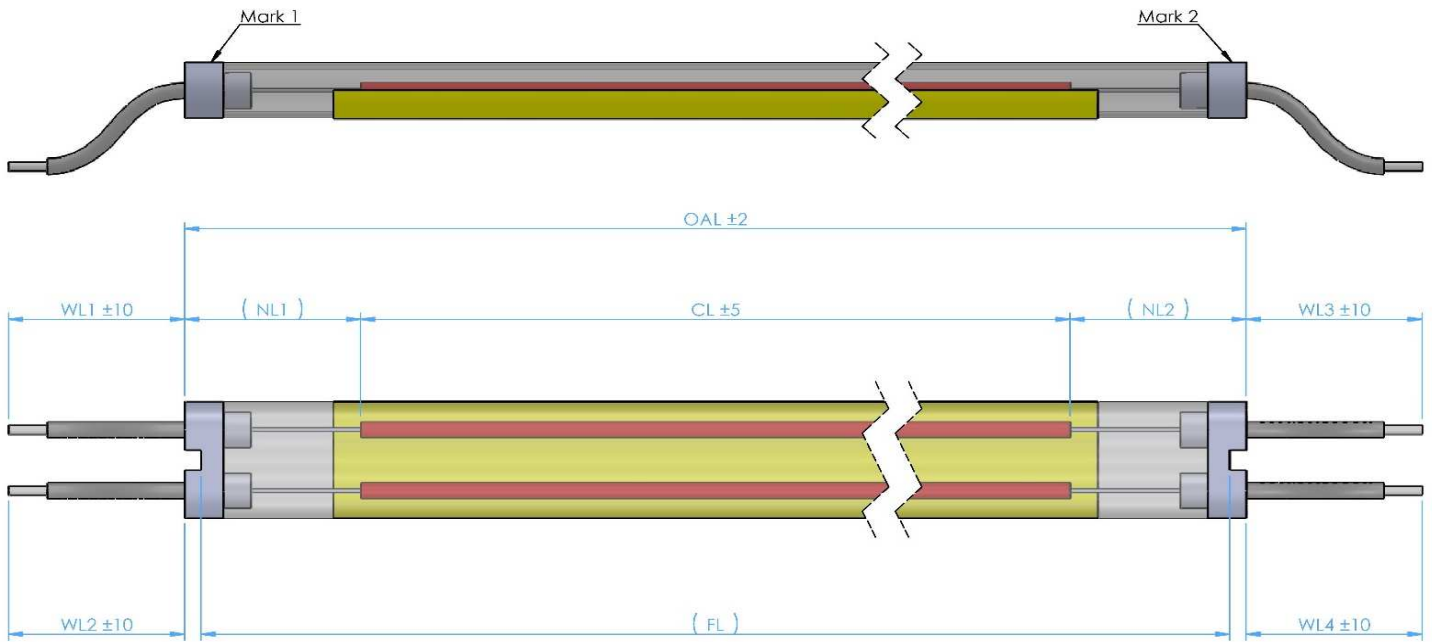

### 1° - Electrical data :

Nominal voltage	Wattage	Average life time*	Wire T°	Lighting position
230 V	2500 W ± 5%	10000 Hrs	850 °C	Horizontal ±4°

\* with AC power supply, 50 or 60 Hz, continuously at room temperature and free from vibration.

### 2° - Dimensional data :

OAL	CL	FL	NL1	NL2
1300 ± 2 mm	1200 ± 5 mm	(1294 mm)	(50 mm)	(50 mm)

### 3° - Cable data :

Cable Type	Terminal	WL 1	WL 2	WL 3	WL 4
Silicable CNVAS 1mm <sup>2</sup> 400° (grey) OMERIN or equivalent	End Stripped (7mm)	500 ± 10mm	500 ± 10mm	500 ± 10mm	500 ± 10mm

### 4° - Marking :

Mark 1	Mark 2
DHKG230V2500W 1200S11KH	DIRTECH + Lot

Emitter type
C

<b>Twin Tube Medium Wave Emitter</b>			Modif	0					
			Date	21/03/2016					
<b>DHKG 230V 2500W 1200 S11 K - H</b>			Comments						
Date	DIRTECH®	Drawing number		Original					
21/03/2016		IRM-159							